

**Seginus Inc.** is pleased to introduce J1212P03EH, J1212P04EH, J1212P05EH **Self-Locking Nuts**

# FAA PMA

OEM Part Numbers:  
J1212P03, J1212P04,  
J1212P05

PMA Part Numbers:  
J1212P03EH, J1212P04,  
J1212P05

Quantity Per Unit:  
Various

Installation:  
Various GE CF34,  
GE CF6, CFMI CFM56  
Engines & Boeing and  
Embraer airframes

CMM Reference:  
Various

The Self-Locking Nuts  
**P/Ns J1212P03, P04, P05** are  
parts of the GE, CFMI Engines and  
Embraer, Boeing Airframes and  
Sub- assemblies.

Seginus Inc has released the  
following FAA PMA replacement  
part to aid in your cost reduction  
programs when maintaining  
installation applications in GE,  
CFMI engines and Embraer, Boeing  
Subassemblies and Airframes.

**J1212P03EH, J1212P04EH,  
J1212P05EH Self-Locking Nuts**

For additional information, contact  
our USA offices or your regional  
distributor.

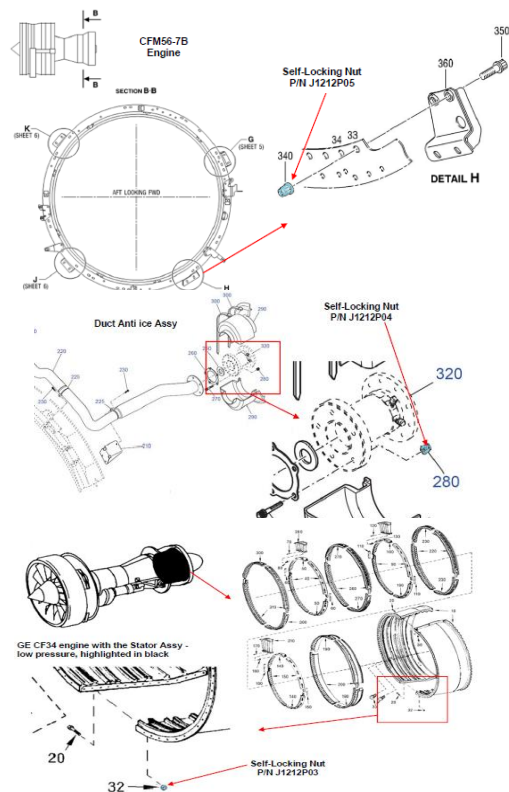

Scan for more  
information or log on  
[www.seginusinc.com](http://www.seginusinc.com)

114 Kirkland Circle  
Suite B  
Oswego, IL 60543

Tel: 630-800-2795  
Fax: 630-800-2097

Also check out our  
company page on  
LinkedIn.

