



# 产品规格书

PRODUCT SPECIFICATION

客户名称Buyer Name	
客户料号Buyer Part No.	
客户承认签章 Buyers Approval & Signatures	

文件编号Spec No.	S-525113	版本	A/0
品名描述 Product Description	无刷直流振动马达 BLDC Coin Vibration Motor		
型号Part No.	W0525AB001D		
送样日期Date			
设计Designed by	审核Checked by	批准Approved by	
陳满	陈满	陈满	
2019.3.14	2019.3.14	2019.3.14	

Jinlong Machinery & Electronics  
www.jinlong-machinery.com  
sales@jinlong-machinery.com





部品 型号名 Parts model	W0525 AB001D	业体名 Customer		承认愿 No. Approval request No.	
				制定 / First drawing up	2019.03.14
部品规格 Parts size	Φ5×2.5T	部品名 Product	振动马达 Vibration motor	改正 Revision	Rev.0

◆ CTF (Critical to Factor / Function)

■ 电机特性(or光学特性) / Electrical characteristics (or optical characteristics)

项目/ Item	Spec	CPK	备注/ Remark
额定转数 Spin speed	14,000 ±3,000 rpm	1.38	全数检查实施 Total inspection
额定损耗电流 Operating consumption current	80 mA 以下/ Below 80 mA	1.67	全数检查实施 Total inspection
启动电压 Starting voltage	DC 2.5V 以下/ Below DC 2.5V	2.35	全数检查实施 Total inspection

■ 形合部尺寸/ Shape measurements

项目/ Item	Spec	CPK	备注/ Remark
完成品高度 Product height	2.5mm± 0.1mm	1.75	
完成品直径 Product Ø	Ø5± 0.05mm	2.43	

■ 外观/ Appearance

- CASE 无变形及生锈现象 / Case : No dent and rust
- F-PCB 无变形及位置扭曲现象 / PCB : No dent and twist

◆ 开发阶段重要 ISSUE 事项 / Major issues in development stage

■ 开发阶段issue事项 / Major issues in development stage

- 
- 

■ 初度量产时, 必须确认的邀请事项

■ Request list of essential confirmation for the first mass production

-

部品 型号名 Parts model	W0525 AB001D	业体名 Customer		承认愿 No. Approval request No.	
部品规格 Parts size	Φ5×2.5T	部品名 Product	振动马达 Vibration motor	改正 Revision	2019.03.14 Rev.0

## 2. 产品说明/ Product explanation

### 2-1. 适用范围 / Application range

本规格书适用于无刷马达W0525AB001D系列.

This specification applies to BLDC type motors model

### 2-2. ~~W0525001D~~ 测试环境条件 / Measurement environment condition

No.	项目 / Item	规格 / Standard
2-2-1	温度 / Temperature	25°C± 3°C
2-2-2	湿度 / Humidity	65% ± 20%RH
2-2-3	气压 / Atmospheric pressure	1,013 hpa ± 40 hpa

### 2-3. 使用环境 / Environment of use

No.	项目 / Item	规格 / Standard
2-3-1	使用电压范围 The range of working voltage	2.7 ~ 3.3 V
2-3-2	保管温度范围 The range of temperature of storage	-40°C ~ +85°C There should be no condensation
2-3-3	使用温度范围 The range of temperature of use	-20°C ~ +60°C There should be no condensation 在-5°C 和+25°C 对比 3-3 项 正常转速随着温度降低 -20%

### 2-4. 实验误差范围 / The range of errors in test

No.	项目 / Item	规格 / Standard
2-4-1	常温/常湿 / Room temperature / humidity	25±15°C / 65±20%RH
2-4-2	恒温组温度/ Temperature in the thermostat	规定值 ±3°C / Designated level ±3°C
2-4-3	电压/ Voltage	规定值 ±0.15V / Designated level ±0.15V

部品 型号名 Parts model	W0525 AB001D	业体名 Customer		承认愿 No. Approval request No.	2019.03.14
				制定 / First drawing up	
部品规格 Parts size	Φ5×2.5T	部品名 Product	振动马达 Vibration motor	改正 Revision	Rev.0

### 3. 产品特性/ Product features

#### 3-1. 电机特性 / The electronic features

No.	项目 / Item	条件 / Condition	规格 / Standard
3-1-1	额定电压 Rated voltage		DC 3.0V
3-1-2	旋转方向 Rotation	Lead Wire Red(+), Blue(-)连接基准 Based on connecting lead wire Red(+), Black(-)	CW
3-1-3	额定转数 Rated speed	遵从4项标准测定条件 Based on No, 4 standard measurement condition	14,000±3,000 rpm
3-1-4	额定损耗电流 Rated current	遵从4项标准测定条件 Based on No, 4 standard measurement condition	Below 80 mA
3-1-5	启动电流 Starting current	在额定电压下把旋转子固定 此时消耗的电流测定 Measuring the consumption current when the rotor starts at operating voltage	Below 175 mA
3-1-6	启动电压 Starting voltage	使马达能够启动的最小电压 (ON, OFF 试验) (ON, OFF实验) The minimum current that can start the motor(ON, OFF test)	Below DC 2.5V
3-1-7	绝缘电阻 Insulation resistance	Case和 Lead wire 端子间 DC 100V施加100V DC in put, between case and F-PCB	Above 10MΩ

#### 3-2. 机构特性 / The mechanical features

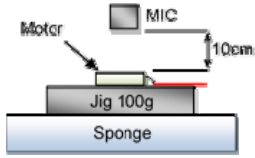
No.	项目 / Item	条件 / Condition	规格 / Standard
3-2-1	震动量 Vibration strength	 <ul style="list-style-type: none"> <li>- 电压voltage : DC 3.0V</li> <li>- Jig weight : 100g</li> <li>- JIG放置在 Sponge 上测定</li> <li>- 马达用两面tape固定在jig中</li> </ul>	0.25 G(Avg)
3-2-2	机械 噪音 Mechanical noise	 <ul style="list-style-type: none"> <li>- Background noise below 28dB</li> <li>- Standard voltage : DC 3.0V</li> <li>- To install jig on the sponge</li> <li>- Measuring after attaching the motor with double-sided tape</li> </ul>	50dB 以下
3-2-3	重量 / Weight	使用电子秤测量 / Measuring with the electronic scale	0.32g±10%
3-2-4	Motor 耐压力	Not to have to have malfunctions in features when accredit the external weight based on front side	3.0kgf 以下

部品 型号名 Parts model	W0525 AB001D	业体名 Customer	承认愿 No. Approval request No.		
				制定 / First drawing up	2019.03.14
部品规格 Parts size	Φ5×2.5T	部品名 Product	振动马达 Vibration motor	改正 Revision	Rev.0

#### 4. 测定方法 / Measurement method

No.	项目	Spec
4-1	温度 / Temperature	25± 3°C
4-2	湿度 / Humidity	65 ± 20% RH
4-3	额定电压 / Operating voltage	DC 3.0V

4-4 测定方法 / Measurement method

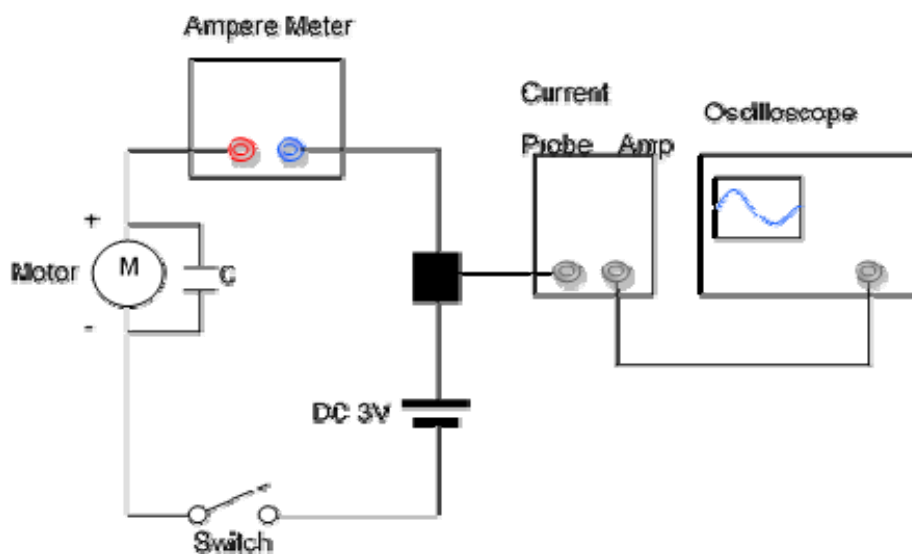

检查回路图 / Testing circuit diagram



- Install jig on the sponge pad
- Fix the motor inner side of jig

标准测定状态  
The condition of standard measurement

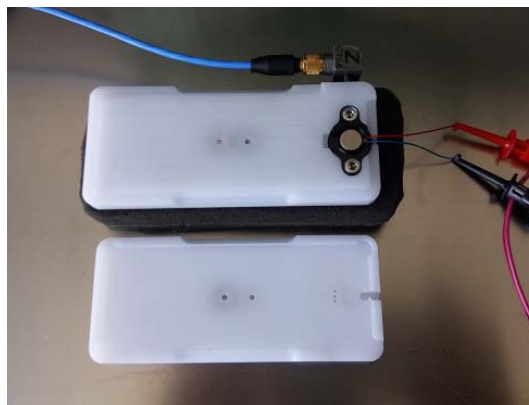

- Jig weight : 100g
- Material : POM

马达安插状态  
The condition of motor settlement

部品 型号名 Parts model	W0525 AB001D	业体名 Customer		承认愿 No. Approval request No.	
部品规格 Parts size	Φ5×2.5T	部品名 Product	振动马达 Vibration motor	改正 Revision	2019.03.14 Rev.0

## 5. 回路图,Part list / Circuit diagram and part list

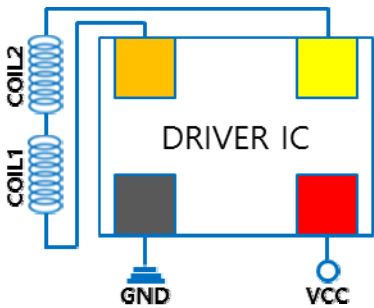
回路图 / Circuit diagram	Spec
	<p>霍尔片通过内置的Drive IC向Coil供电,Coil产生电磁力,此电磁力与转子rotor上magnet的磁力产生作用,此时机壳上的霍尔IC内置Drive IC感应到magnet极性,从而间断向coil供应电流使转子连续转动。</p> <p>The Coil receives current from Drive IC which include whole element. It makes coil get electric force. This electric power and magnet force of installed magnet in Rotor make revolution by Fleming's left hands law.</p> <p>While it happens, the Rotor can spin continually by whole element in Rotor supply current to Coil alternatively through whole element notices magnetic pole.</p>

No.	Parts	Materials
1	BRACKET	SUS304
2	DOUBLE-SIDE TAPE	DT7605-45 (0.045t)
3	DRIVE IC	Si
4	F-PCB	EPOXY,FR-4(0.1t)
5	COIL ASS'Y	Copper wire
6	WASHER	POLYSLIDER
7	SHAFT	DSR7B
8	OILLESS BEARING	SIM
9	YOKE	SPCC
10	CAPACITOR	CHIP IC
11	MAGNET	Nd-Fe-B
12	C/WEIGHT	W
13	CASE	SPCC



部品 型号名 Parts model	W0525 AB001D	业体名 Customer	承认愿 No. Approval request No.	Page 9 / 14
部品规格 Parts size	Φ5×2.5T	部品名 Product	制定 / First drawing up 2019.03.14	
		振动马达 Vibration motor	改正 Revision	
			Rev.0	

### 6. 图面 / Drawing

**Top View:** Shows a circular motor with a diameter of  $4.2 \pm 0.05$  mm. The label '0525' is printed on the top surface. Two lead wires are shown: a red wire labeled 'Lead Wire(AWG32) Red(+)' and a black/blue wire labeled 'Black(or Blue) Wire(-)'. The distance between the wire attachment points is  $1.5 \pm 0.03$  mm.

**Side View:** Shows the motor's profile with a diameter of  $\phi 5.0 \pm 0.05$  mm and a height of  $2.5 \pm 0.1$  mm. A 'Double-side tape (SK 800P Tape:0.1mm+Release paper:0.1mm)' is applied to the bottom. A maximum height of  $Max 2.0$  mm is indicated for the motor body.

**DETAIL "A" (S=15/1):** A magnified view of the motor's internal structure, showing a diameter of  $2.2 \pm 0.01$  mm, a length of  $1.8$  mm, and a gap of  $0.4$  mm. Other dimensions include  $0.5$  mm and  $1.0$  mm.

**Label numbering:** A diagram shows the '0525' label with dimensions: Diameter (?), Thickness(mm), and a table of options.

Diameter (?)	Φ10→10 Φ9→9, Φ5→5, .....
Thickness (mm)	3.0mm→30, 2.7mm→27, 2.5mm→25, ...

**Specification:**

Voltage(V)		Rated Speed (rpm)	Rated Current (mA)	Min Starting Voltage (V)
Operating Range	Rated voltage	14,000±3,000	80 Max	2.5 Max
2.7~ 3.3	3.0			

**Revision Table:**

REV	ORIGINATOR	APPROVED	MODIFICATION DETAILS				DATE
	UNIT	SCALE	TOLERANCE	MATERIAL	FINISH	DATE	☺ 3RD ANGLE PROJECTION
	mm	8:1	±0.2			2019.03.14	File name
	DRAW	DESIGN	CHECK	APPROVED	MODEL	W0525AB001D	
		H.Y.SUI 2019.03.14	H.DONG 2019.03.14	S.E.LEE 2019.03.14	NAME	BLDC VIBRATION MOTOR	
					DWG. NO		

部品 型号名 Parts model	W0525 AB001D	业体名 Customer	承认愿 No. Approval request No.		
				制定 / First drawing up	2019.03.14
部品规格 Parts size	Φ5×2.5T	部品名 Product	振动马达 Vibration motor	改正 Revision	Rev.0

## 7. 包装式样 / Packing specification

### 7-1. 适用范围 / The arrange of application

本包装式样书适用于BLDC型震动马达 $\phi 5 \times 2.5 \text{mm}$

This packing specification is applied to  $\phi 5 \times 2.5 \text{mm}$  vibration motor which is used as a BLDC vibration motor.

### 7-2. 内, 外径包装规格 / The packing standard

项目 / Item	Spec			
	Material	Size (mm)	包装数量 / Packing Qty	包装后重量 Weight after packing
Tray 包装	PET	328(L) $\times$ 240(W) $\times$ 9.5(H)	100ea Max	About 70g
Out box 包装	DW-1	510(L) $\times$ 350(W) $\times$ 175(H)	5,000ea Max	About 5.2Kg

### 7-3. 包装图 / Packing drawing

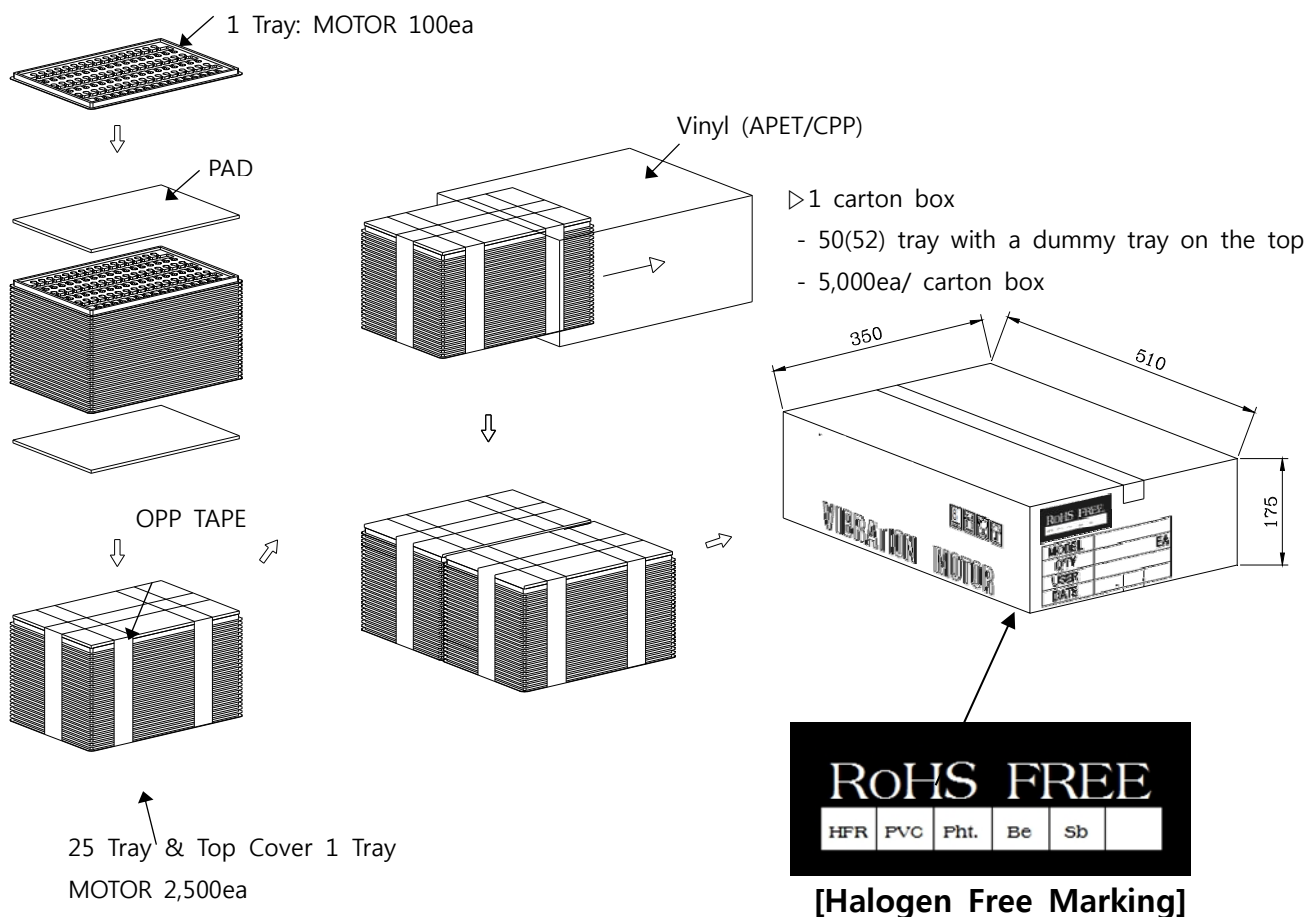

部品 型号名 Parts model	W0525 AB001D	业体名 Customer		承认愿 No. Approval request No.	2019.03.14
				制定 / First drawing up	
部品规格 Parts size	Φ5×2.5T	部品名 Product	振动马达 Vibration motor	改正 Revision	Rev.0

**8. 信赖性实验规格**

No.	项目	测定条件	评价基准																
8-1	耐久寿命 Life test	<p>-施加电压 DC 3.0V, 以2秒 On 1秒 Off为 1 cycle进行1,000,000次后, 在常温常湿下放置2小时后测定.</p> <table border="1"> <tr> <th>电压</th> <th>温度</th> <th>湿度</th> <th>寿命</th> </tr> <tr> <td>DC 3.0V</td> <td>25±15°C</td> <td>65±20% RH</td> <td>1,000,000</td> </tr> </table> <p>-After operating 2 seconds on and 1 seconds off 1,000,000 times by applied Voltage DC3.0V, test in Room temperature 2hours later.</p> <table border="1"> <tr> <th>Voltage</th> <th>Temperature</th> <th>Humidity</th> <th>Life</th> </tr> <tr> <td>DC 3.0V</td> <td>25±15°C</td> <td>65±20% RH</td> <td>1,000,000</td> </tr> </table>	电压	温度	湿度	寿命	DC 3.0V	25±15°C	65±20% RH	1,000,000	Voltage	Temperature	Humidity	Life	DC 3.0V	25±15°C	65±20% RH	1,000,000	<p>-额定转数: 初期值+40%,-20%以内</p> <p>-其它电机特性: 要满足3-1项.</p>
电压	温度	湿度	寿命																
DC 3.0V	25±15°C	65±20% RH	1,000,000																
Voltage	Temperature	Humidity	Life																
DC 3.0V	25±15°C	65±20% RH	1,000,000																
8-2	高温高湿 动作实验 High Temperature Humidity Life	<p>- 1 Cycle: 90 sec On, 30 sec Off 1440 Cycles</p> <table border="1"> <tr> <th>电压</th> <th>温度</th> <th>湿度</th> <th>Test 时间</th> </tr> <tr> <td>DC 3.0V</td> <td>50°C</td> <td>95% RH</td> <td>48Hr</td> </tr> </table> <p>-在常温常湿下放置2小时后测定. 3.0V 90s on/30s off , 1440 Cycles +50°C,95%RH,48Hr test In Room temperature 2hours later.</p> <table border="1"> <tr> <th>Voltage</th> <th>Temperature</th> <th>Humidity</th> <th>Test time</th> </tr> <tr> <td>DC 3.0V</td> <td>50°C</td> <td>95% RH</td> <td>48Hr</td> </tr> </table>	电压	温度	湿度	Test 时间	DC 3.0V	50°C	95% RH	48Hr	Voltage	Temperature	Humidity	Test time	DC 3.0V	50°C	95% RH	48Hr	<p>Rated Spin Number : Should be in ±40%, -20% from initial value</p> <p>- Other electronic features : Should meet clause 3-1</p>
电压	温度	湿度	Test 时间																
DC 3.0V	50°C	95% RH	48Hr																
Voltage	Temperature	Humidity	Test time																
DC 3.0V	50°C	95% RH	48Hr																
8-3	低温保管实验 Low Temperature Storage Test.	<p>-20°C条件下,保存2小时, 常温常湿条件下放置2小时时候测定 Store at -20°C for 2hrs Test after 2hrs in Room Temperature.</p>	<p>-额定转数: 初期值±20% 以内.</p> <p>-其它电机特性: 要满足3-1项</p>																
8-4	高温高湿实验 High Temperature and Humidity Test.	<p>在+50°C, 95%RH条件下,放置120小时, 常温常湿条件下放置2小时时候测定 Store at +50°C and 95% RH for 120hrs. Test after 2hrs in Room Temperature and Humidity</p>	<p>-Rated Spin Number :Should be in ±20% from initial value</p> <p>- Other electronic features : Should meet clause 3-1</p>																

部品 型号名 Parts model	W0525 AB001D	业体名 Customer		承认愿 No.	2019.03.14
				Approval request No.	
部品规格 Parts size	Φ5×2.5T	部品名 Product	振动马达 Vibration motor	改正 Revision	Rev.0

No.	项目	测定条件	评价基准																
8-5	热冲击实验 Thermal Shock Test	-40°C和 +85°C,各2小时,一共20cycles构成 常温常湿条件下放置2小时候测定 Operating at - 40°C for 60min and +85°C for 60min (20cycles) test after 2 hrs in room temperature.	-额定转数: 初期值±20% 以内. -其它电机特性: 要满足3-1项 -Rated Spin Number :Should be in ±20% from initial value - Other electronic features : Should meet clause 3-1																
8-6	落下实验 Drop Test	在大约100g Dummy SET上安装MOTOR后, 从152cm 高度,正面/反面各20次,侧面各10次 总80次落下后测定 After installing motor in 100g Dummy set, drop the dummy from 152cm height. Test after drop total 80 times(Front : 20 times/Back : 20 times/4 Sides : 10times for each side)	-额定转数: 初期值±25% 以内 -其它电机特性: 要满足3-1项. -无外观构造的变形,裂开,部品无脱离现象. -无TOUCH声音发生现象.																
8-7	连续落下实验 Continuous Drop Test	在大约100g Dummy SET上安装MOTOR后, 从100cm高度100次, 从50cm 高度200次落下后测定 After installing motor in 100g Dummy set,100cm 100 cycles, 50cm 200cycles	-Rated Spin Number : Should be in ±25% from initial value. - Other electronic features : Should meet clause 3-1 -Should not have transformation, cracks and part deviations. Should not make the touch sound																
8-8	高温/低温动作实验 High/Low Temperature Movement Test	-高温动作: +25 ~ 70°C, 5°C单位别测定. -低温动作: 0 ~ -20°C, 5°C单位别测定. 各温度别放置5分钟后测试 <table border="1" data-bbox="411 1637 1023 1809"> <thead> <tr> <th>状态</th> <th>电压</th> <th>测定项目</th> <th>固定方法</th> </tr> </thead> <tbody> <tr> <td>水平</td> <td>DC 3.0V</td> <td>转数 震动量</td> <td>STEEL JIG DOUBLE SIDE TAPE</td> </tr> </tbody> </table> <table border="1" data-bbox="411 1928 1023 2078"> <thead> <tr> <th>Position</th> <th>Voltage</th> <th>Test Item</th> <th>Fixing Method</th> </tr> </thead> <tbody> <tr> <td>horizontality</td> <td>DC 3.0V</td> <td>RPM</td> <td>STEEL JIG Double side TAPE</td> </tr> </tbody> </table> -High Temperature Operating: +25 ~ 70°C, Test at every 5°C. -Low Temperature Operating: 0 ~ -20°C, Test at every 5°C	状态	电压	测定项目	固定方法	水平	DC 3.0V	转数 震动量	STEEL JIG DOUBLE SIDE TAPE	Position	Voltage	Test Item	Fixing Method	horizontality	DC 3.0V	RPM	STEEL JIG Double side TAPE	各温度单位别 RPM 变化值测定.(参照用) Measuring alteration of RPM at each degree (For Reference)
状态	电压	测定项目	固定方法																
水平	DC 3.0V	转数 震动量	STEEL JIG DOUBLE SIDE TAPE																
Position	Voltage	Test Item	Fixing Method																
horizontality	DC 3.0V	RPM	STEEL JIG Double side TAPE																



部品 型号名 Parts model	W0525 AB001D	业体名 Customer		承认愿 No.	
				Approval request No.	
				制定 / First drawing up	2019.03.14
部品规格 Parts size	Φ5×2.5T	部品名 Product	振动马达 Vibration motor	改正 Revision	Rev.0

## 9. 产品安装建议事项及注意事项

9-1.与规格不同使用的情况下,性能和寿命会发生问题.希望注意电压使用范围.

You might encounter functional and life problems if you use it different from the standard. Please be careful of the range of use, like voltage etc.

9-2. MOTOR使用时,一定要把图纸上的 lead wire (+)端子连接在 (+), (-) 端子连接在(-)后使用.

No matter what please connect red lead wire to (+) socket, and blue and black lead wire to (-) socket when you use the motor.

9-3. 在有害GAS及高温高湿的场所保管对马达造成不良因素所以请注意保管.

Please be careful of that the storage in high temperature and humidity and noxious gas might causing adverse to motors.

9-4.为了减少马达旋转时因检查失误电源端子短路时导致 Drive IC 损伤。为了防止损伤 Drive IC 电源端子间 (+, -) 把 2μF 以上的电容器并列链接 在 Motor 后实施检查是安全措施

Drive IC can be damaged by power plug short due to careless test. In order to prevent damage of Driver IC, please connect 2μF condenser to motor in a row(parallel connection) with power plug(+/-).

9-5.拿取马达时,尽可能的轻拿Case部分.

Please hold the case part lightly as much as you can when you use motors.

9-6.为保护 Drive IC, 请不要施加DC 4.5V以上.

9-7.马达接近磁性物质或接触时会降低马达性能, 因此避免接近强磁场.

Please avoid being near and contacting magnetic materials like magnet which might encounter functional problems.

9-8.能够自我吸附的物质 (铁, 粉末) 及灰尘等与马达混放时会出现转动不良, 异常音等, 会使马达的性能下降及信赖性受影响,因此取用及作业时应注意环境清洁.

If some materials(metal, powder) and dust become mixing condition in the motor it might cause feature declines by occurring rotation faulty and abnormal sound so please be clean the working environment and careful when you deal with the motor.

9-9.注意请不要浸泡在液态物质如 : 水或酒精中

Please be careful of not soaking in liquid like water or alcohol.

9-10.包装方法 : (参照包装图) 只有在客户要求下变更可能.

Packing method : Refer to packing drawing. But, it could be changed on user's demand.

9-11.无法保证满足本式样范围以外使用的情况.

It can't guarantee if the motors are used out of the range of fulfilling this specification.

9-12.本式样书内容的变更及追加是在双方协议下实施.

Any further conditions or change of this APPROVAL REQUEST take effect by mutual consent.